

**PETITE
FRITURE**
EDITEUR DE DESIGN

COLLECTION
01 / 2016

Furniture, lighting, accessories

PETITE FRITURE

French design manufacturer established in 2009, PETITE FRITURE aims to produce objects, lighting and furniture that create a spark, designed by emerging talents.

With their complicity, **PETITE FRITURE** offers elegant and accessible products that in a simple and uninhibited manner tell a story; products that understand our daily life and invite us to savour it.

COLLECTION

01 / 2016

Furniture, lighting, accessories



LIFESTYLE

AURA	p.11	p.33-34	ISO - A & ISO - B
NARCISO	p.12	p.35	PARROT
FRANCIS	p.13	p.36	CHERRY
LESS	p.14	p.37-38	MASK
GRID	p.15-16	p.39	BUBBLE
MARKET	p.17-18	p.40	BAMBOU
ÉTOILE	p.19	p.41	MOIRE
PETSTOOLS	p.20	p.42	WILD CAR
ANT	p.21	p.43	OBJETS 2822
JOIN	p.22	p.44	VERTIGO
GRANDISSANT	p.23	p.45-46	TRAME
WILD THINGS	p.24	p.47	OTHERWISE EQUAL
JUNGLE	p.25	p.48	MINERA
NUBILO	p.25-26	p.49	CANDLE TORCH
VARIATIONS	p.27-28	p.50	TIDELIGHT
BASIL	p.27-28	p.51-52	HOLLO
LANTERNA	p.29	p.53-54	GRILLO
LOOP	p.30	p.55	BRILLE
CURIOSITY	p.31-32		

TECHNICAL SPECIFICATIONS

AURA	p.74	p.63	ISO - A & ISO - B
NARCISO	p.84	p.64	PARROT
FRANCIS	p.72	p.76	CHERRY
LESS	p.79	p.71	MASK
GRID	p.69-70	p.79	BUBBLE
MARKET	p.65-66	p.81	BAMBOU
ÉTOILE	p.80	p.76	MOIRE
PETSTOOLS	p.67	p.85	WILD CAR
ANT	p.80	p.81	OBJETS 2822
JOIN	p.82	p.73	VERTIGO
GRANDISSANT	p.87	p.60	TRAME
WILD THINGS	p.85	p.88	OTHERWISE EQUAL
JUNGLE	p.89	p.81	MINERA
NUBILO	p.68	p.88	CANDLE TORCH
VARIATIONS	p.89	p.78	TIDELIGHT
BASIL	p.62	p.61	HOLLO
LANTERNA	p.75	p.77	GRILLO
LOOP	p.70	p.83	BRILLE
CURIOSITY	p.84		



- 01 — Amandine Chhor & Aïssa Logerot
- 02 — Andreas Engesvik
- 03 — Arthur Leitner
- 04 — Céline Frébault
- 05 — Claesson Koivisto Rune
(Ola Rune, Eero Koivisto, Marten Claesson)
- 06 — Constance Guisset
- 07 — Daniel • Emma (Daniel To and Emma Aiston)
- 08 — Elise Fouin
- 09 — Federico Floriani
- 10 — Gaëlle Gabillet & Stéphane Villard
- 11 — Giorgia Zanellato
- 12 — Goliath Dyèvre & Quentin Vaulot
- 13 — Hanna Emelie Ernsting
- 14 — India Mahdavi
- 15 — Jean-Charles Amey
- 16 — Marc Sarrazin
- 17 — Mark Braun
- 18 — Milia Seyppel
- 19 — Noé Duchaufour - Lawrance
- 20 — Pierre Favresse
- 21 — POOL (Léa Padovani & Sébastien Kieffer)
- 22 — Sam Baron
- 23 — Studio Nocc
(Jean-Christophe Orthlieb & Juan Pablo Naranjo)
- 24 — Thomas Jenkins
- 25 — Tiphaine de Bodman
- 26 — Tomas Kral



AURA
TOMAS KRAL

AURA is a pendant lamp in a rolled metal sheet which plays with light in the same way as a delicate lace veil.

TECHNICAL SPECIFICATION – see p.74

+ MARKET – Noé Duchaufour - Lawrance – see p.17 - 18

NARCISO
ECAL / GIORGIA ZANELATO

Draw attention to the role of flowers by using Narciso and its mirrored stainless steel.

TECHNICAL SPECIFICATION – see p.84



NEW PRODUCT

FRANCIS
CONSTANCE GUISET

Coming from experiences with pigments diluted in water, Francis is an echo of an ageing mirror with its bright oxidation.

TECHNICAL SPECIFICATION – see p.72



LESS
MILIA SEYPPEL

Less is the ultimate reduction of a clock to the essential, the simplest manner to tell us time.

TECHNICAL SPECIFICATION – see p.79

GRID POOL

The GRID sofa designed by studio POOL can shift and adapt according to your needs. Provided with modular and graphic elements (the leather cushions and a wooden tablet) this sofa can take on different shapes: as a two or three seater, with or without the tablet, or as a daybed.

TECHNICAL SPECIFICATION – see p.69 - 70





MARKET
NOÉ DUCHAUFOUR - LAWRENCE

Market, designed by Noé Duchaufour - Lawrence, is a range of furniture that is inspired by the wooden lattices that form market stalls. Its simple design makes it easy to match with our everyday interior. Market's element of surprise comes from its the different use of materials: a combination of oak and recycled leather which produces a remarkably genuine aspect.

TECHNICAL SPECIFICATION – see p.65 - 66

+ LANTERNA & CURIOSITY – Sam Baron (left page) – see p.29 / 31



ÉTOILE
CLAESSON KOIVISTO RUNE

This chopping board is above all about geometry, when a carved pattern becomes more than an ornament and embodies a function.

TECHNICAL SPECIFICATION – see p.80



PETSTOOLS
HANNA EMELIE ERNSTING

Petstools are not only stools, but delightfully playful and cosy companions.

TECHNICAL SPECIFICATION – see p.67



ANT
SAM BARON

An ant prisoner of a glass sphere tells us a story : when the invisible becomes visible.

TECHNICAL SPECIFICATION – see p.80

JOIN
MARK BRAUN

Join is a stackable table set that serves our needs and pleasure in everyday life with its beautiful contrast between pure terracotta and coloured glazes.

TECHNICAL SPECIFICATION – see p.82

+ MARKET – Noé Duchaufour - Lawrance – see p.17 - 18



GRANDISSANT
JEAN-CHARLES AMEY

Thought as an organic candleholder, Grandissant alludes to the image of trees structure, and invites us to change its shape to our ideal.

TECHNICAL SPECIFICATION – see p.87



WILD THINGS
PIERRE FAVRESSE

This container gives a fantastic sensorial experience hidden under the shape of an innocent but strange and wild animal.

TECHNICAL SPECIFICATION – see p.85



JUNGLE
TIPHAINE DE BODMAN

The Jungle wallpaper, signed by Tiphaine de Bodman, brings your home to life in an exotic atmosphere.

TECHNICAL SPECIFICATION – see p.89



NUBILO
CONSTANCE GUISET

Nubilo is a dreamlike destination, where the soft and round cushions can be easily arranged to ensure your comfort.

TECHNICAL SPECIFICATION – see p.68

+ BASIL – Arthur Leitner – see p.27 - 28

VARIATIONS
TIPHAINE DE BODMAN

From distilled water to a cluster of dots, this wallpaper will have your head in the clouds.

TECHNICAL SPECIFICATION – see p.89

BASIL
ARTHUR LEITNER

With an aerial structure that plays with the density of the geometrical tabletop, Basil tables were born from the wish to use cork's natural qualities.

TECHNICAL SPECIFICATION – see p.62

+ *WILD THINGS – Pierre Favresse – see p.24*





LANTERNA
SAM BARON

From a simple lamp to a recollection of Chinese rounded lantern, the pendant lamp Lanterna with its golden heart is a tribute to light.

TECHNICAL SPECIFICATION – see p.75

LOOP
AMANDINE CHHOR

A poetic shelf with beautiful curves inspired by constraints of industrial production of trolley.

TECHNICAL SPECIFICATION – see p.70

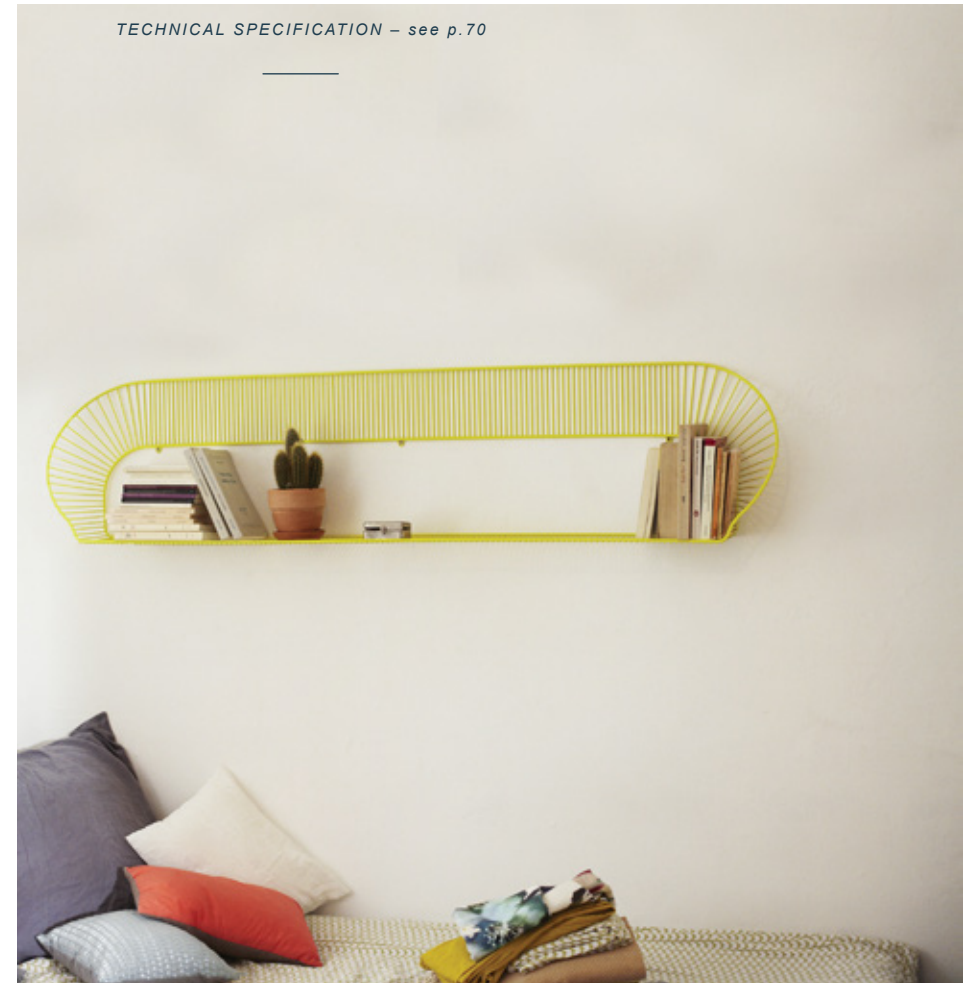



CURIOSITY
SAM BARON

With a humouristic reference to hunting trophies, Curiosity make a surprising hop in your interior.

TECHNICAL SPECIFICATION – see p.84





**ISO - A & ISO - B
POOL**

With its strong graphism, Iso plays with perspectives and volumes.

TECHNICAL SPECIFICATION – see p.63



PARROT
INDIA MAHDAVI

An orange-red foot combined with a colorful and geometric tabletop, bring to life chatty tables.

TECHNICAL SPECIFICATION – see p.64



CHERRY
DANIEL • EMMA

Head over heels or Cherry on the bottom, with the new Cherry pendant-lamps the designers, from Daniel • Emma studio, enhance light with the irised cherry and its conical hat.

TECHNICAL SPECIFICATION – see p.76



MASK
FEDERICO FLORIANI

Like a painted mask over a shaman's face, the graphic lines of the mirrors give a good twist to your reflection.

TECHNICAL SPECIFICATION – see p.71

BUBBLE
VAULOT & DYÈVRE

Popped out straight from Vaulot & Dyèvre's imagination, the Bubble hangers are like soap bubbles frozen and solidly fixed forever.

TECHNICAL SPECIFICATION – see p.79



BAMBOU
CÉLINE FRÉBAULT

Inspired by nature, the salt and pepper set is like two transparent branches set on the table.

TECHNICAL SPECIFICATION – see p.81



MOIRE
MARC SARRAZIN

Thought of as a garment, the moiré effect of the textile sublimates the atmosphere by creating a diffused light.

TECHNICAL SPECIFICATION – see p.76

WILD CAR
PIERRE FAVRESSE

The organic scaly form of this moneybox evokes a universe that is at once familiar yet remote.

TECHNICAL SPECIFICATION – see p.85



OBJETS 2822
GAËLLE GABILLET &
STÉPHANE VILLARD

These black glass decanters invite you to create your own products or use refillable products.

TECHNICAL SPECIFICATION – see p.81



VERTIGO
CONSTANCE GUISET

Movement, illusion, lightness, surprise... Vertigo reduces space to an intimate atmosphere and comes to life when draughts make it slightly lose its balance.

TECHNICAL SPECIFICATION – see p.73



TRAME
AMANDINE CHHOR &
AÏSSA LOGEROT

Two main tracks come in a curve together to create this comfortable armchair.

TECHNICAL SPECIFICATION – see p.60

+ VERTIGO – Constance Guisset – see p.44





OTHERWISE EQUAL
THOMAS JENKINS

Aluminum, stainless steel and brass, each item has the same mass but not the same height due to their difference of density. This is a poetic way to emphasize materials.

TECHNICAL SPECIFICATION – see p.88



MINERA
STUDIO NOCC

The Minera water jug is inspired by a smooth pebble on which crystals have aggregated, the water flows on the uneven side like a small stream.

TECHNICAL SPECIFICATION – see p.81



CANDLE TORCH
ANDREAS ENGESVIK

With its protective shape Candle Torch gives the flame a powerful glow and a magical touch.

TECHNICAL SPECIFICATION – see p.88



TIDELIGHT
PIERRE FAVRESSE

Hand blown in a mould, Tidelight's texture and shape increase light's diffusion and striped glow.

TECHNICAL SPECIFICATION – see p.78



NEW COLOUR

OUTDOOR

HOLLO
AMANDINE CHHOR & AÏSSA LOGEROT

The Hollo tables and stool are a tribute to industrial codes with a shape that gives priority to use and function.

TECHNICAL SPECIFICATION – see p.61



GRILLO
ELISE FOUIN

The wall lamp Grillo is a simple perforated circle that refracts and dims light like a solar eclipse. Grillo exists in two versions : the wall lamp with a simple electrical point connected directly to the wall, and the wall lamp embellished by a colored cable (switch and plug) providing a great liberty to set up the lamp as it suits you.

TECHNICAL SPECIFICATION – see p.77

+ *BASIL (NEW COLOUR) – Arthur Leitner – see p.27 - 28*



BRILLE
PETITE FRITURE

Petite Friture transcribes on this old fashioned striped bowl in a universal language the French expression « Boire du petit lait ».

TECHNICAL SPECIFICATION – see p.83

Glossary



IP ratings are the specifications or 'code' that grade the protection factor given to any light fitting against the touching of live parts (electrical) and protection against the access of solid items/bodies. In addition, the code specifies protection against the harmful ingress of liquids to the light fitting.

Each IP code, has two digits to define its level of protection.

- 1st digit : protection against the access of solid items/bodies (2 = protection against the access of solid items > 12,5mm)
- 2nd digit: protection against the harmful ingress of liquids (0 = unprotected)



The CE mark indicates that a product meets the requirements of relevant EEC directives **EN 60 598-1** and **EN 60 598-1-2**. Its prime purpose is to facilitate its free trading and movement within the EEC. It's also a safety and quality proof.



Max power - CE marking:

Our lightings comply with the CE mark within the limits of suitable bulb.



The Glow Wire Test simulates thermal stresses which may be produced by such sources of heat or ignition. The test certifies that the tested product is non inflammable between 0° et the maximum indicated temperature.



Quantity of packages



Flat pack



Packed by 2



Outdoor



High resistance



Assembly



Base bulb



U.K. Cable

See p.45-46



TRAME

AMANDINE CHHOR & AÏSSA LOGEROT
CHAIR

Coated steel, grained epoxy paint

Polyester

CHAIR

L: 53.5cm; W: 44cm; H: 76.5cm (back); h: 43.5cm (seat)
W: 8kg

Colours : Black / White / Grey / Yellow

CUSHION

L: 41.5cm; W: 33cm; H: 2cm

Colours : White / Medium grey / Black

Standards : 

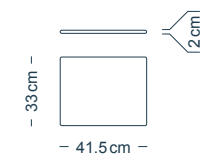
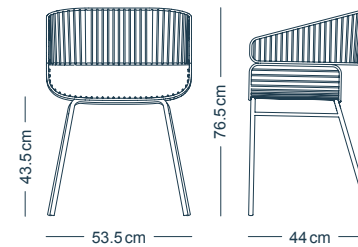

See p. 51 - 52



HOLLO

AMANDINE CHHOR & AÏSSA LOGEROT
STOOL & TABLES

Coated steel, grained epoxy paint

TABLE FOR TWO

Ø: 50 cm; H: 72 cm
W: 7 kg

COFFEE TABLE

Ø: 70 cm; H: 33 cm
W: 12 kg

STOOL OR SIDE TABLE

Ø: 35 cm; H: 44 cm
W: 4 kg

Colours : Blue / Burgundy / Gold /
Anthracite / Black

Standards : 

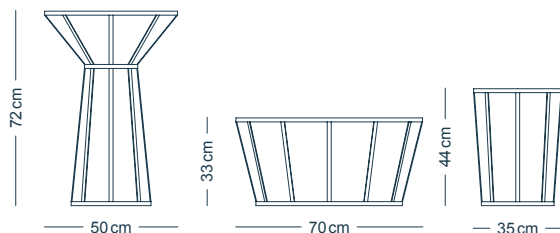

See p. 27 - 28



BASIL

ARTHUR LEITNER
SIDE TABLES

Cork, steel, grained epoxy paint

TRAPEZE

L: 49 cm; W: 49 cm; H: 46.5 cm
W: 6 kg

SPHERE

Ø: 47 cm; H: 46.5 cm
W: 6 kg

PYRAMID

L: 54 cm; W: 54 cm; H: 46.5 cm
W: 4 kg

Colours : White - natural cork /
Black - black flecked cork

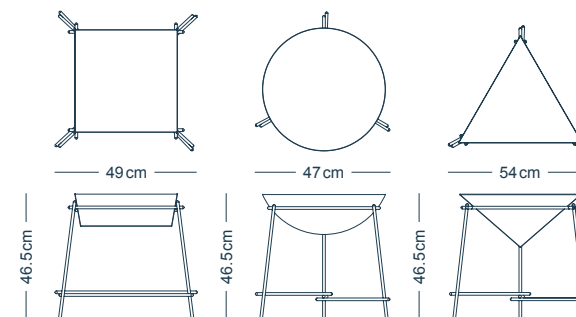

See p. 33-34



ISO-A & ISO-B
POOL
 (LÉA PADOVANI & SÉBASTIEN KIEFFER)
 SIDE TABLES

Coated steel, grained epoxy paint

ISO-A (ROUND)
 Ø: 47 cm; H: 44 cm
 W: 5 kg

ISO-B (SQUARE)
 L: 40 cm; W: 40 cm; H: 42.5 cm
 W: 5 kg

Colours : Black / White / Blue / Burgundy

Standards :

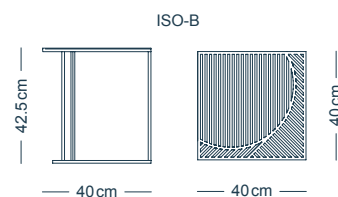
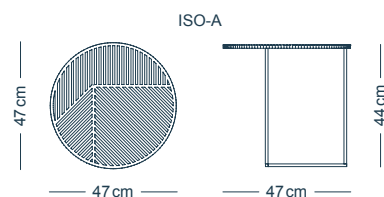

See p. 35

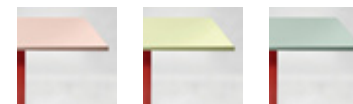

PARROT
INDIA MAHDAVI
 TABLES

Enameled steel, coated steel, epoxy paint

SMALL
 L: 90 cm; W: 90 cm; H: 73 cm
 W: 39 kg

Standards : x2

Colours : Light pink /
 Light turquoise /
 Light yellow

LARGE
 L: 200 cm; W: 90 cm; H: 73 cm
 W: 80 kg

Standards : x3

Colours : Light pink /
 Light turquoise /
 Light yellow

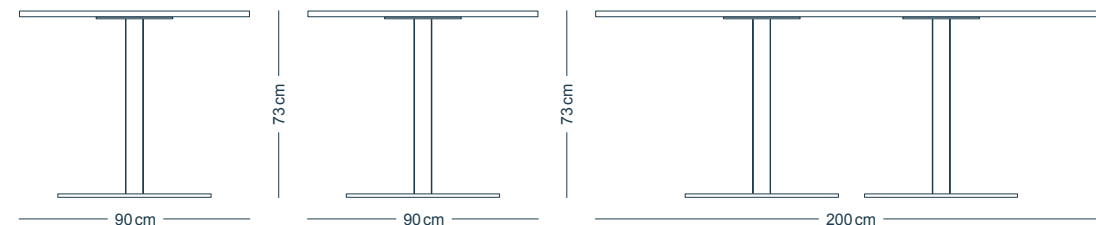

See p. 17-18



MARKET

NOÉ DUCHAUFOR-LAWRANCE

CHAIR / BENCH / TABLES

Solid oak, recycled leather (the tabletop is waterproof)

BENCH

L: 124 cm; W: 40 cm; H: 45 cm
W: 10 kg

Standards :

CHAIR

L: 50 cm; W: 58 cm; H: 84 cm (back); h: 45 cm (seat)
W: 7 kg

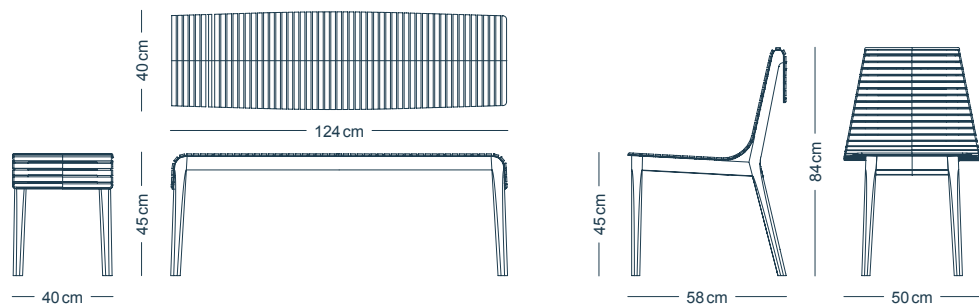

SQUARE TABLE

L: 71 cm; W: 71 cm; H: 74 cm
W: 15 kg

Standards :

ROUND TABLE

Ø: 105 cm; H: 74 cm;
W: 23 kg

Standards :

RECTANGULAR TABLE

L: 142 cm; W: 71 cm; H: 74 cm
W: 25 kg

Standards :

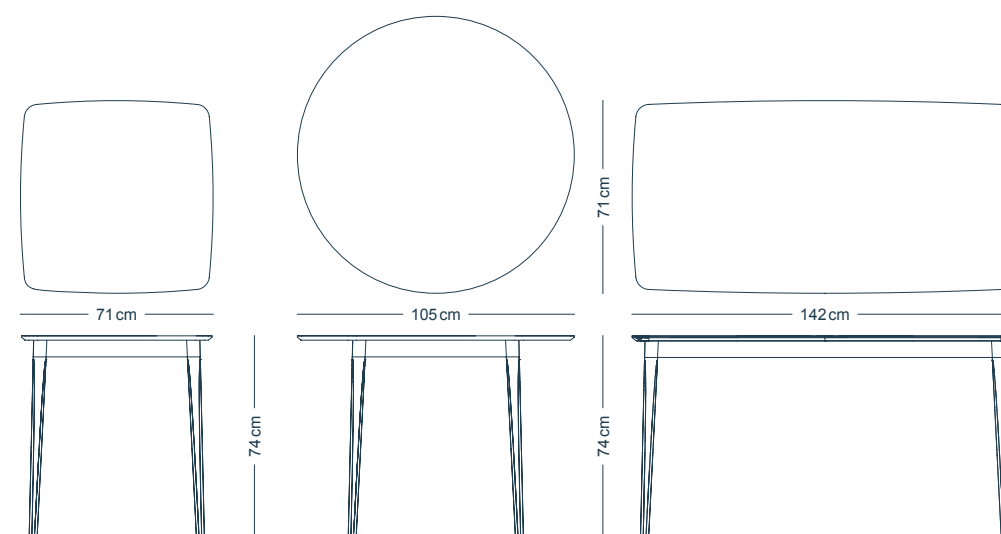

See p.20



PETSTOOLS
HANNA EMELIE ERNSTING
STOOLS

Wool, nylon, polyester, wood, steel, foam

Ø: 48 cm; H: 60 cm; h: 35 cm (seat)

W: 3 kg

Colours : *Fin - Light grey /
Ella - Anthracite grey /
Daisy - Pink*

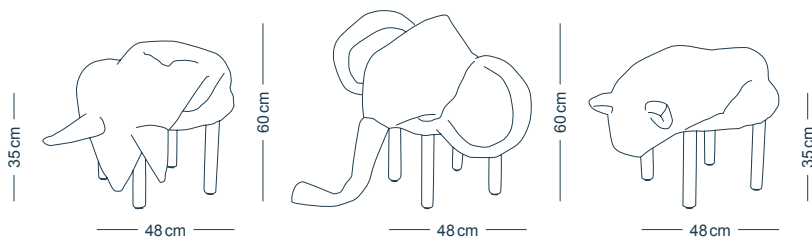

See p.25-26

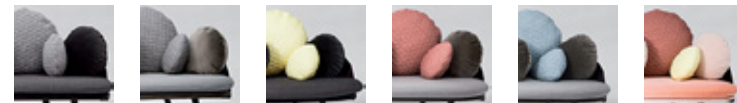

NUBILO
CONSTANCE GUISSSET
ARMCHAIR / SOFA

Coated steel, wool, velvet, polyester foam

ARMCHAIR

L: 77 cm; W: 70 cm; H: 65 cm (back); h: 40 cm (seat)

W: 20 kg

Colours : *Black - Grey /
Beige - Beige /
Black - Yellow /
Beige - Coral /
Beige - Turquoise /
Red - Coral, White, Yellow*

SOFA

L: 155 cm; W: 75 cm; H: 65 cm (back); h: 40 cm (seat)

W: 50 kg

Colours : *Black - Grey /
Beige - Beige /
Black - Yellow /
Beige - Coral /
Beige - Turquoise /
Red - Coral, White, Yellow*

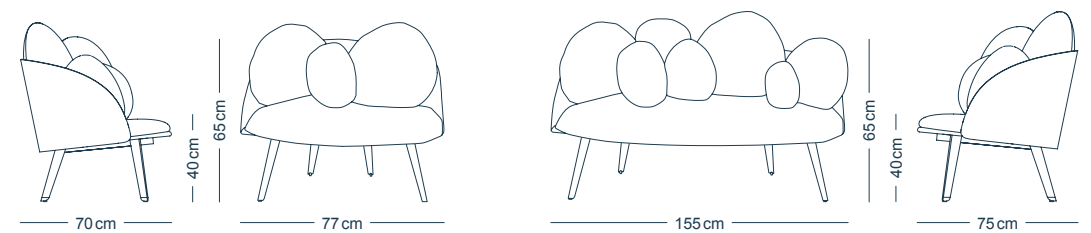

See p. 15-16

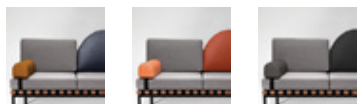

GRID
POOL
SOFA/ DAYBED

Coated steel, wool, walnut wood, leather, polyester foam

WITH TABLET

L: 187cm; W: 72cm; H: 86cm (back); h: 45cm (seat)
W: 45kg

Colours : Grey - Dark blue, mustard /
Grey - Brick, coral /
Grey - Grey, black

WITHOUT TABLET

L: 140cm; W: 72cm; H: 86cm (back); h: 45cm (seat)
W: 40kg

Colours : Grey - Dark blue, mustard /
Grey - Brick, coral /
Grey - Grey, black

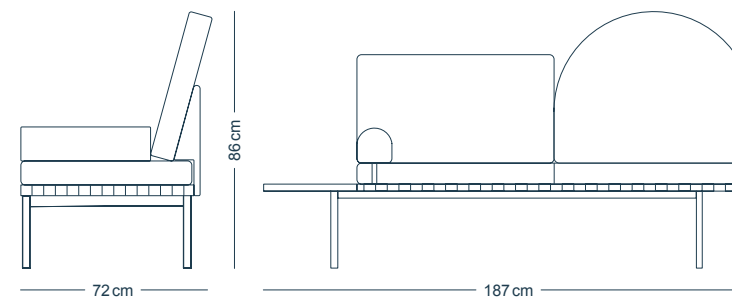
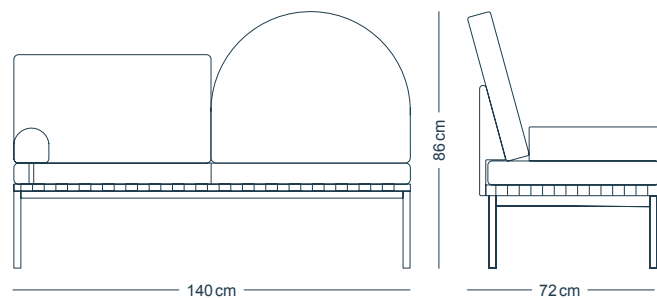

See p. 37-38

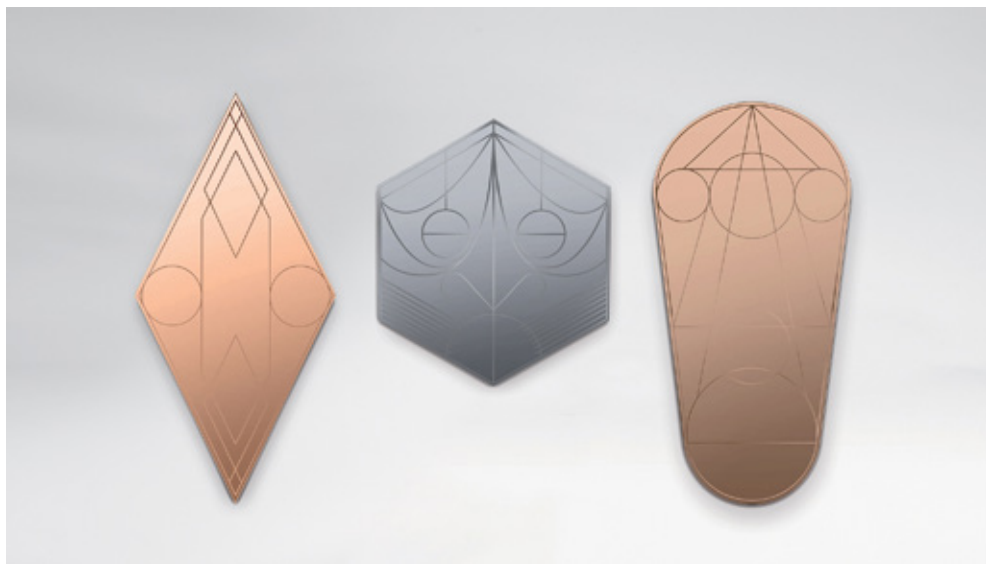

MASK
FEDERICO FLORIANI
WALL MIRRORS

Tinted lacquered mirror

RHOMBUS
W: 60 cm; H: 120 cm
W: 5 kg
Colour : Coral

HEXAGON
W: 65 cm; H: 75 cm
W: 5 kg
Colour : Lead

OVAL
W: 60 cm; H: 120 cm
W: 9 kg
Colour : Bronze

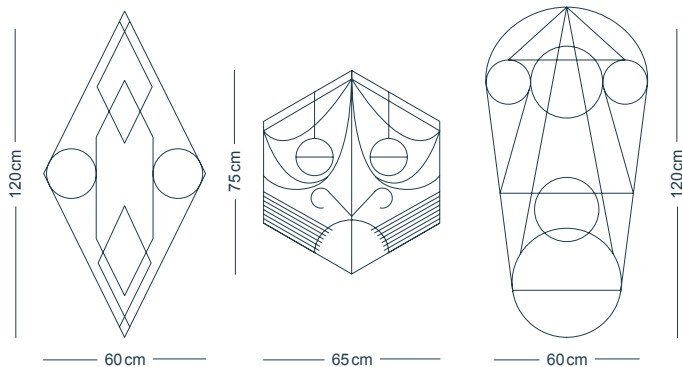

See p. 13



FRANCIS
CONSTANCE GUISET
WALL MIRROR

Mirror, aluminum, grained epoxy paint

Ø: 60 cm; W: 5 cm
W: 7 kg

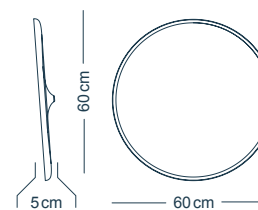

See p. 30

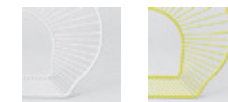

LOOP
AMANDINE CHHOR
SHELF

Steel, grained epoxy paint

L: 160 cm; W: 15 cm; H: 34.5 cm
W: 4.5 kg

Colours : White / Yellow

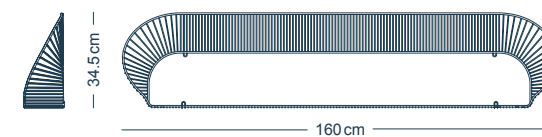

See p. 44



VERTIGO
CONSTANCE GUISET
 PENDANT LAMPS

Fiberglass, iron, polyurethane

SMALL / Ø: 140cm; H: 15cm
LARGE / Ø: 200cm; H: 17cm
 W: <0.5kg

Colours : Green / Copper / Black /
 White / Light pink / Light Blue

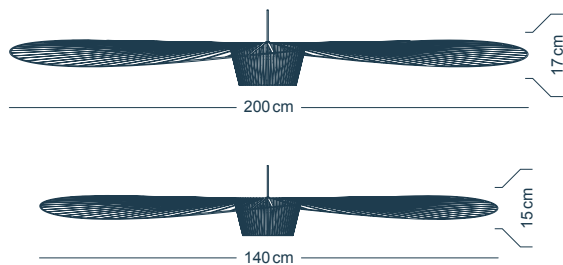

See p. 11



AURA
TOMAS KRAL
 PENDANT LAMPS

Grained epoxy paint aluminum, smooth epoxy paint steel

SMALL / Ø: 33cm; H: 17cm
 W: 0.8kg

LARGE / Ø: 63cm; H: 22.5cm
 W: 1.8kg

Colours : Beige / Dark blue /
 Green / Coral

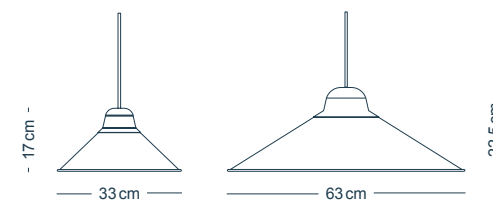

See p.29



LANTERNA

SAM BARON
PENDANT LAMPS

Lacquered steel, cotton, PVC

SMALL / Ø: 22cm; H: 42cm
W: 0.4kg

MEDIUM / Ø: 47cm; H: 60cm
W: 0.8kg

LARGE / Ø: 75cm; H: 50cm
W: 1.2kg

Colours : Black - Gold / White - Gold

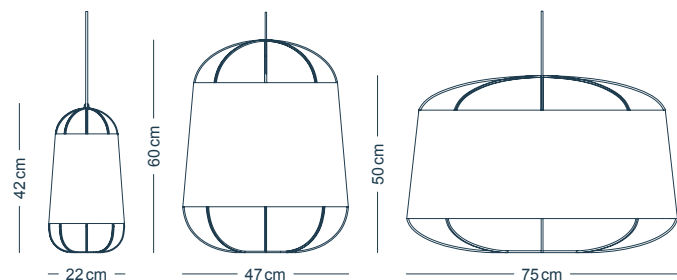

See p.41

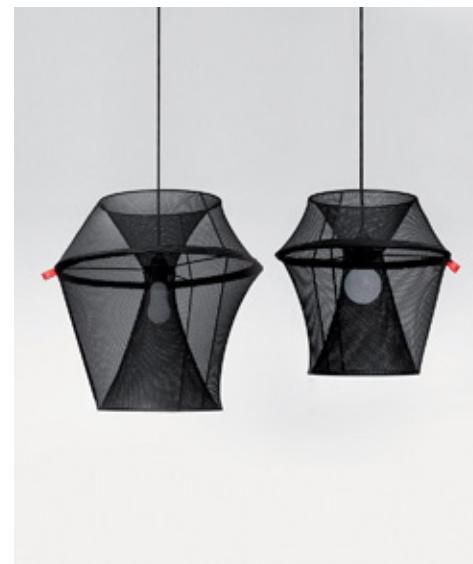

MOIRE

MARC SARRAZIN
ADAPTABLE LAMPS

Polyester, lacquered copper, grained epoxy paint

SMALL / Ø: 35cm; H: 35cm
W: 0.7kg

LARGE / Ø: 50cm; H: 50cm
W: 0.8kg



Colours : Black / White

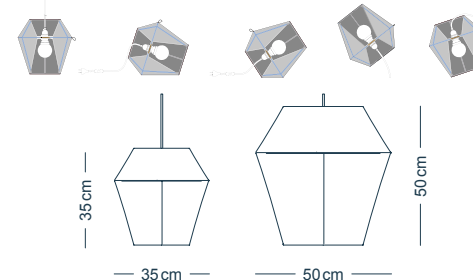

See p.36



CHERRY

DANIEL • EMMA
PENDANT LAMPS

Aluminum, grained epoxy paint, mirror finish steel, plexiglass

SMALL / Ø: 16cm; H: 37.5cm
W: 0.5kg

LARGE / Ø: 50cm; H: 37.5cm
W: 2kg



Colours : Black - Rainbow / White - Gold

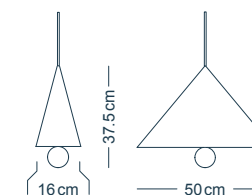

See p. 53-54



GRILLO

ELISE FOUIN
WALL LAMPS

Coated steel, grained epoxy paint

SMALL / Ø: 23cm; W: 10cm
W: 0.3kg

LARGE / Ø: 36cm; W: 10cm
W: 0.6kg

Standards :



220-240V 50-60Hz

Colours : *White - Fluo Yellow*
White - Fluo Pink
White - White
White - Teal Green

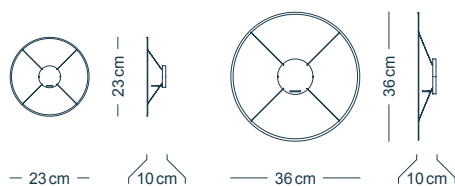

WALL LAMPS WITH CABLE (SWITCH AND PLUG)

Coated steel, grained epoxy paint, textile cable

SMALL / Ø: 23cm; W: 10cm
W: 0.3kg

LARGE / Ø: 36cm; W: 10cm
W: 0.6kg

CABLE / L: 300cm

Standards :

220-240V 50-60Hz

Colours : *White - Fluo Yellow*
White - Fluo Pink
White - White
White - Teal Green

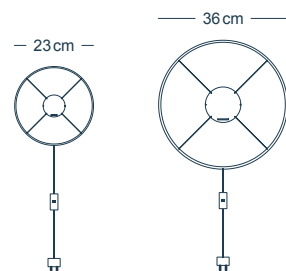

See p. 50



TIDELIGHT

PIERRE FAVRESSE
TABLE / FLOOR LAMPS

Blown glass, cork

Ø: 30cm; L: 26.5cm; H: 26.5cm
W: 2kg

Standards :

220-240V 50-60Hz

Colours : *Smoked / Transparent*

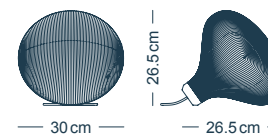

See p. 40



BUBBLE
VAULOT & DYÈVRE
HANGERS

Blown glass, steel

SMALL / L: 9.5cm; W: 9.5cm; H: 7.5cm
W: 0.25kg

LARGE / L: 13cm; W: 15cm; H: 13cm
W: 0.35kg

Colours : Coral / Grey / Yellow / Blue

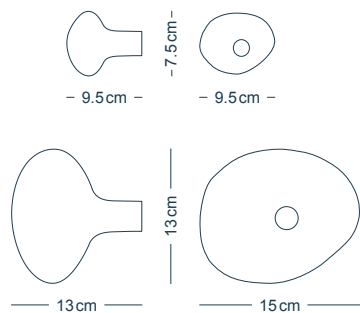

See p. 14



LESS
MILIA SEYPPPEL
CLOCK

Brass, anodized aluminum

L: 26cm (clock's hand); W: 3.4cm
Max. Ø: 52cm
W: 0.15kg

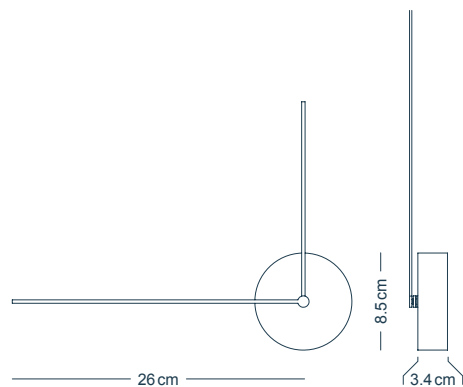

See p. 21



ANT
SAM BARON
PAPERWEIGHT

Glass

Ø: 8cm
W: 0.6kg



See p. 19

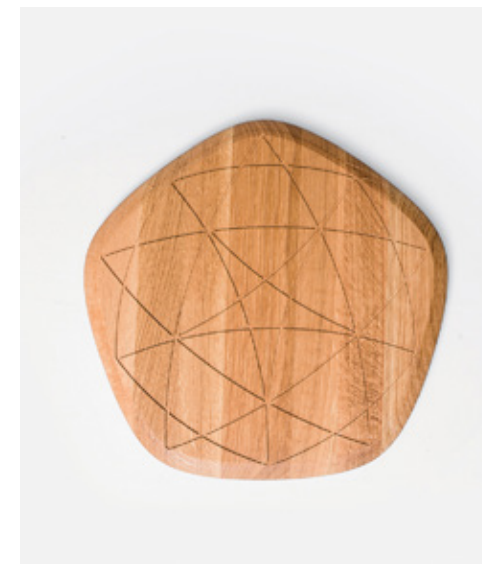

ÉTOILE
CLAESSON KOIVISTO RUNE
CHOPBOARD

Oak

L: 36cm; W: 36cm; H: 2cm
W: 1.3kg

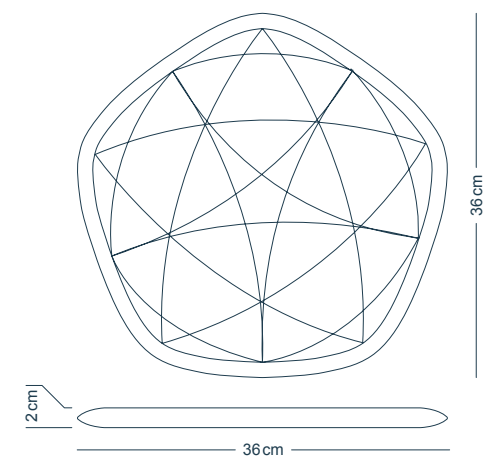

See p. 40

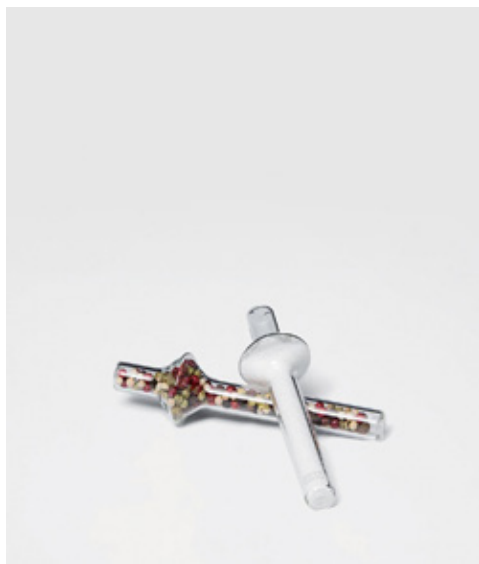

BAMBOU

CÉLINE FRÉBAULT
SALT & PEPPER SHAKERS (THE PAIR)

Borosilicate glass

Ø: 3.5cm; Ø: 1cm; L: 13cm
W: 0.03kg (each)

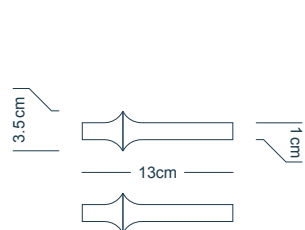

See p. 43



OBJETS 2822

GAËLLE GABILLET & STÉPHANE VILLARD
DOMESTIC DECANTERS

Black glass

SMALL / Ø: 8cm; H: 9cm
W: 0.25kg
0,25 L

LARGE / Ø: 8cm; H: 17.5cm
W: 0.5kg
0,5 L

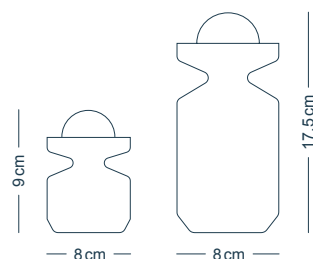

See p. 22



JOIN

MARK BRAUN
TABLEWARE

Enameled terracotta

ESPRESSO CUP / Ø: 6.5cm; H: 5.5cm
W: 0.1kg

MUG / Ø: 10cm; H: 8.5cm
W: 0.2kg

BOWL / Ø: 15cm; H: 4.5cm
W: 0.3kg

Colours : Blue / Yellow / Pink

SERVING BOWL / Ø: 25.5cm; H: 7.5cm
W: 0.9kg

SIDE PLATE / Ø: 22cm; H: 1.7cm
W: 0.4kg

PLATE / Ø: 25.5cm; H: 2cm
W: 0.5kg

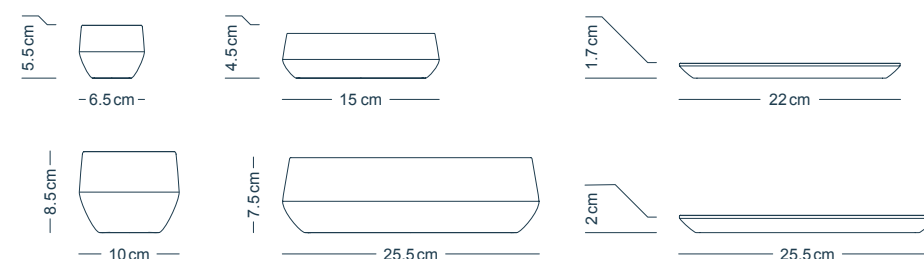

See p. 55



See p. 48



See p. 12



See p. 12



BRILLE
PETITE FRITURE
BOWLS

Ceramic

SMALL / Ø: 10 cm; H: 6.5 cm; 0.2L
LARGE / Ø: 15 cm; H: 9.5 cm; 0.5L

Standards : 

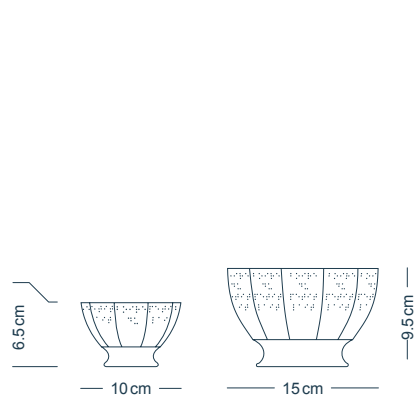

MINERA
STUDIO NOCC
CARAFE

Glass

L: 11 cm; W: 7.5 cm; H: 23 cm
W: 0.75 kg
1L

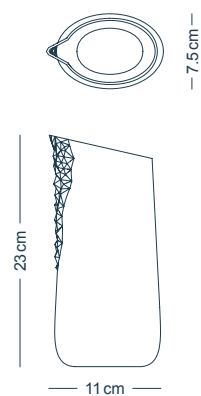

NARCISO
ECAL / GIORGIA ZANELATO
VASES

Glass, mirror polish stainless steel

PIATTO (LOW) / Ø: 30 cm; H: 12 cm
W: 3 kg

CERCHIO (HIGH) / Ø: 31 cm; Ø: 11 cm; H: 60 cm
W: 5 kg

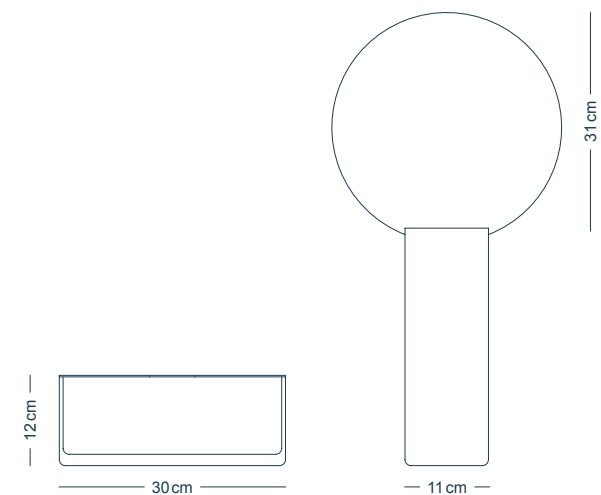

See p. 42



See p. 24



See p. 31



See p. 32



WILD CAR
PIERRE FAVRESSE
MONEYBOX

Porcelain, cork

L: 13.5 cm; W: 7.5 cm; H: 8.5 cm
W: 0.3 kg

WILD THINGS
PIERRE FAVRESSE
CONTAINERS

Porcelain

SMALL / Ø: 10 cm; H: 13 cm
W: 0.6 kg
LARGE / Ø: 10 cm; H: 16 cm
W: 0.7 kg

CURIOSITY
SAM BARON
CONTAINER

Ceramic

Ø: 12.5 cm; H: 28 cm
W: 1 kg

CURIOSITY
SAM BARON
DECORATIVE PLATE

Ceramic

Ø: 27.5 cm
W: >1 kg

Attachment provided.

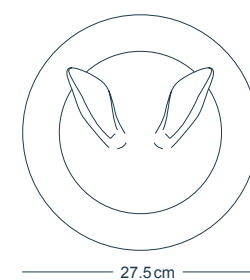
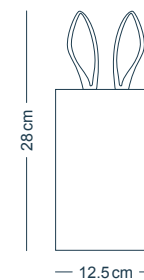
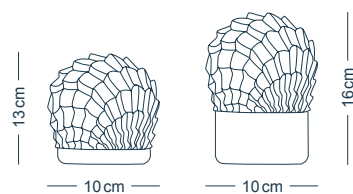
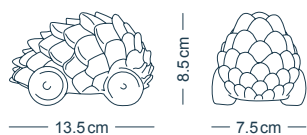

See p.23



See p.23



GRANDISSANT

JEAN-CHARLES AMEY
CANDLE HOLDERS

Concrete

9 modules
Base / L: 51cm; W: 27.5cm; H: 5cm
Module / L: 12cm; H: 14.5cm
W: 6kg

3 modules
Base / Ø: 21cm; H: 5cm
Module / L: 12cm; H: 14.5cm
W: 3kg

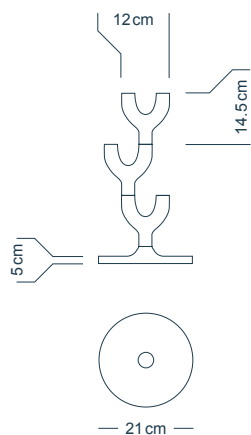
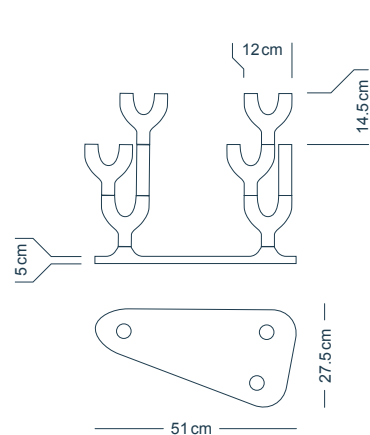

See p.49

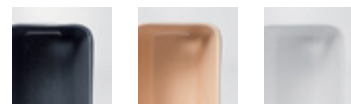

CANDLE TORCH

ANDREAS ENGESVIK
CANDLE HOLDERS

Ceramic

SMALL / L: 7cm; W: 9cm; H: 11cm
W: 0.25kg
LARGE / L: 9cm; W: 10cm; H: 26.5cm
W: 0.35kg

Colours : Grey / Coral / White

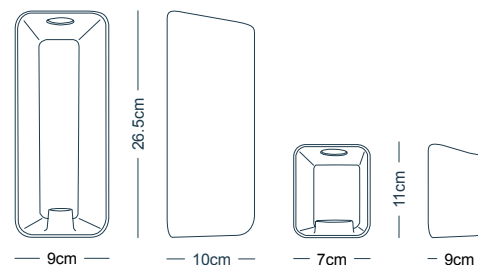

See p.47



OTHERWISE EQUAL

THOMAS JENKINS
CANDLE HOLDERS (SET OF 3)

Brass, stainless steel, aluminium

BRASS / Ø: 3cm; L: 4.5cm
STAINLESS STEEL / Ø: 3cm; L: 5cm
ALUMINUM / Ø: 3cm; L: 12cm
W: 0.2kg (each)

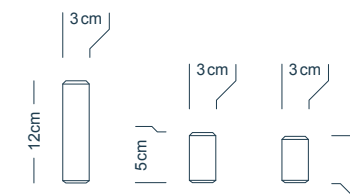

See p.27



See p.25

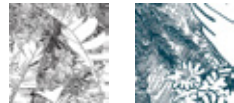

VARIATIONS

TIPHAINE DE BODMAN
WALLPAPER
(STRIPE 1 AND 2 SOLD SEPARATELY)

Non-woven paper

L: 48 cm; H: 300 cm

Colours : *Black / Ink*



- 48 cm -

JUNGLE

TIPHAINE DE BODMAN
WALLPAPER
(STRIPE 1 AND 2 SOLD SEPARATELY)

Non-woven paper

L: 48 cm; H: 300 cm

Colours : *Black / Ink*



- 48 cm -

GRAPHIC DESIGN / LAYOUT
PETITE FRITURE

PHOTOGRAPHY
Ola Rindal (*interior*)
Léa Baert (*stylism*)

PRINTING
Kappadue Arti Grafiche

PETITE FRITURE
*83 boulevard Richard Lenoir,
75011 — Paris
France*

T: +33 (0)1 44 54 13 95
F: +33 (0)1 44 54 02 19

S A L E S
sales@petitefriture.com

petitefriture.com

