

Hartau Series

Hartau Double

Design by Alexandre Joncas

The Hartau series brings together classical light fittings that are, at first glance, astonishing in their line and detail. They have been handmade in Canada using frosted glass, brass and painted aluminium.

The lampshades are the signature of this collection: with their two openings they offer both direct and indirect light to the wall or the ceiling. Each metal part of the Hartau collection is precision made in Quebec, Canada.



Hartau Double

Design by Alexandre Joncas

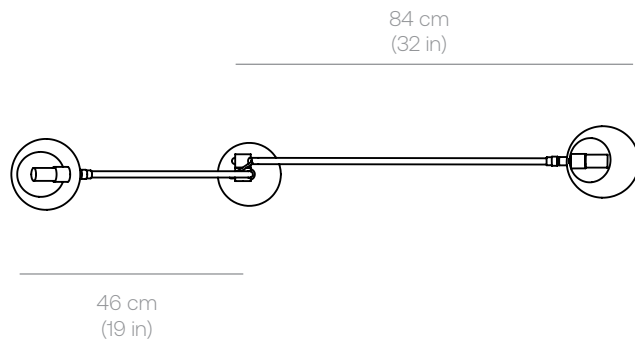
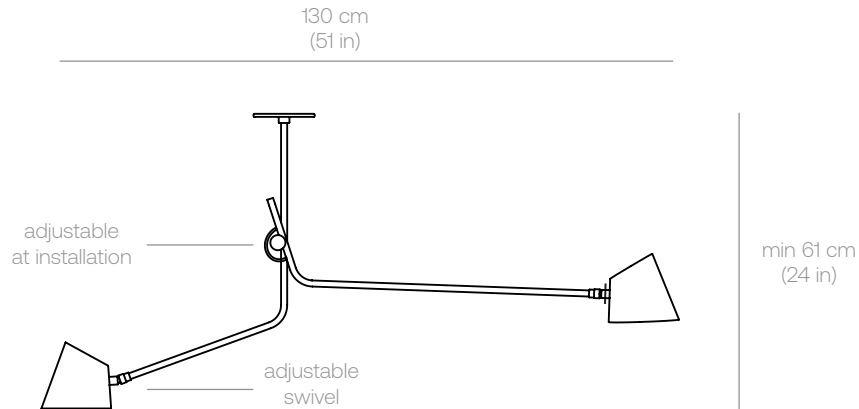

Lamping Specifications

Input voltage : 120V or 220-240V
 Power input : 16W
 Technology : G9 LED bulb (included)
 CRI : >90
 CCT : 3000K (Warm white)
 Lumen source : 700 lm

Product Weight

1.6 kg / 3.6 lbs

Height

A	B	C	D
61 cm (24 in)	89 cm (35 in)	112 cm (44 in)	201 cm (79 in)



**custom height available upon request*

Certifications

IP20  

Materials

Exterior finishes :

-  Matte Black
-  Matte White
-  Custom

Swivels and details finishes :

-  Brass
-  Chrome
-  Black Oxide

Order code generator	Serie	Model	Finish	Details	Voltage	Height	QTY
HA	Hartau	DO Double	BL Matte Black	BR Brass	11 120V	A 61 cm	.
.	.	.	WH Matte White	CH Chrome	21 220-240V	B 89 cm	.
.	.	.	ZZ Custom	OX Black Oxide	.	C 112 cm	.
.	D 201 cm	.
.	Z Custom	.
Order code :	HA	DO	---	---	---	---	---

